

Service Manual

Models:

XJV-E

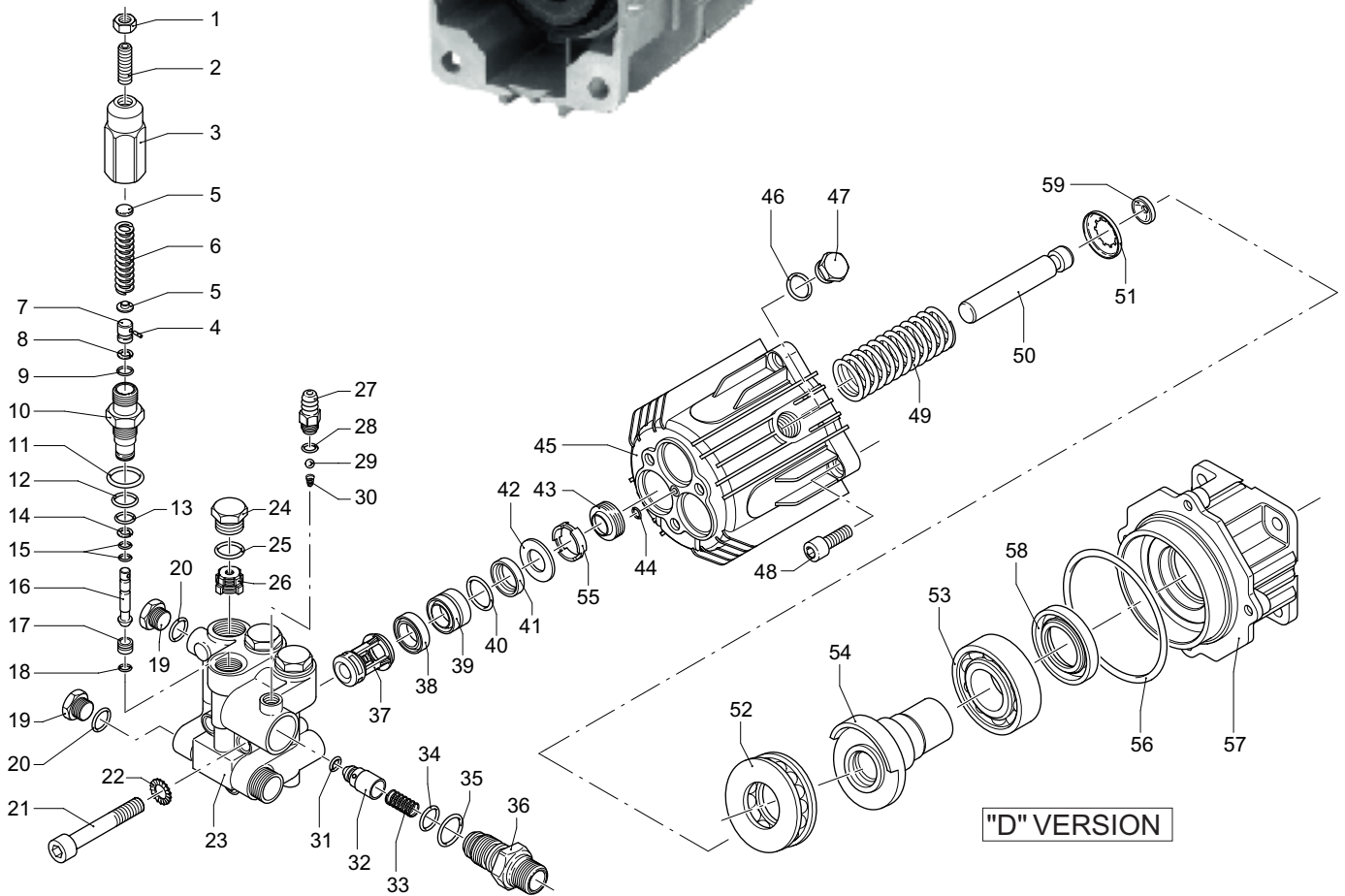

Servicing the Valves

Discharge Valves:

Disassembly:

1. Remove the valve cap
2. Inspect the valve cap O-Ring for any damage, replace if necessary.



3. Using a needle nose pliers remove the valve.



4. Use a small probe to move the poppet up and down to assure that it is functioning properly.
5. Inspect for any debris that may be lodged between the poppet and seat.



6. Remove the valve seat O-Ring and inspect for any damage.



Assembly:

1. Install the valve seat O-Ring squarely into the bottom of the manifold.



2. Insert the valve assembly squarely into the port pushing it into the O-Ring.



3. Install the valve cap and torque to the proper specifications.



Servicing the Valves (cont)

Inlet Valves:

Disassembly:

1. Remove the manifold.



2. Remove low pressure seals, insert screwdriver under seal lip and lift up.



3. Using a reversible pliers, carefully remove the packing retainers (plunger guides). Note: *You do not want to damage these so they can be reused if not worn.*



4. Remove the high-pressure packing by pulling straight out with your finger.



5. Pull out the valve cage/head ring assembly, valve poppet, spring and O-Ring.

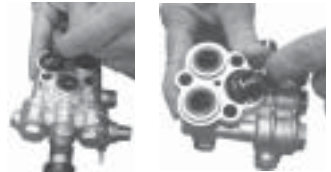

6. Inspect for any debris or damage.



7. Remove the valve O-Ring.



Servicing the Valves (cont)

Assembly:

1. Install the valve seat O-Ring squarely into the bottom of the manifold.



2. Insert the valve assembly and push squarely into the O-Ring.



3. Install the high-pressure packing by placing it into the cylinder at an angle and then pushing into place. Note: *The point of the "V" or flat side of the packing is pointed at you.*



4. Lubricate the packing retainer O-Ring with a light film of oil and install it into the cylinder.
5. Push it completely into place. Note: *The O-Ring will seat just inside the manifold and you will hear a slight pop.*



6. Insert the low pressure seal by placing it into the cylinder in at an angle and pushing it into place.



7. Put a thin coat of oil on the plungers and packings.
8. Carefully install the manifold and torque the bolt to the proper specifications.



Valve life is dependant on many variables. Hard water, cavitation, corrosion, chemicals and equipment care. The valves are a wear item and need periodic replacement. Worn O-Rings or damaged valves will cause pressure loss and pulsations.

Servicing the Packings/Seals

Packings:

Disassembly:

To access the water seals for inspection or replacement, you will first need to remove the head of the pump.

Note: *It is important to make note of the order in which the components of the packing stack are arranged and facing during disassembly.*

1. Remove the head bolts.
2. Insert small pry bars between the head and body at opposite corners and apply pressure down on one pry bar and up on the other pry bar.
3. Lift the head up and away from the body.



Note: *The packing stacks will not always stay in the head of the pump when it is removed. Sometimes one or more components of the packing stack will come out of the head and stay on the plunger.*

4. To remove any components that stay on the plungers simply twist back and forth while pulling up.



5. Remove low pressure seals inert screwdriver under seal lip and lift up.



6. Remove the piston guides from the head by using a reverse plier (preferably rubber coated) inserted into the center of the piston guide.
7. Use a back and forth twisting motion while pulling up (clockwise and counterclockwise).
8. Another method is to use a two-prong slide hammer puller. Insert the prongs into the piston guide allowing the prongs to grab under the support ring then use the slide hammer to pull the packing stack up and out of the head.



Note: *Damage to the piston guides and or the seals may occur during removal. Inspect carefully before reusing any components of the packing stack.*

9. Remove the high-pressure packing by pulling straight out with your finger.



Servicing the Packings/Seals (cont)

Assembly:

1. Install the high-pressure seal into the head. Note: *It should fit snugly. The packing support is part of the valve cage.*
2. Place the high-pressure seal at an angle and work it into the cylinder. (All models). Note: *The point of the "V" or flat side of the packing is pointed at you.*



4. Lubricate the packing retainer O-Ring with a light film of oil and install it into the cylinder. Push it completely into place. Note: *The O-Ring will seat just inside the manifold and you will hear a slight pop.*



5. Insert the low-pressure seal by placing it into the cylinder in at an angle and pushing it into place.



6. Put a thin coat of oil on the plungers and packings.
7. Carefully install the manifold and torque the bolt to the proper specifications.



Valve life is dependant on many variables. Hard water, cavitation, corrosion, chemicals and equipment care. The valves are a wear item and need periodic replacement. Worn O-Rings or damaged valves will cause pressure loss and pulsations.

Note: *Water seals are wear items. Life of the seals is dependent on many factors. Water seals should be replaced when water leak or a loss of performance is noticed. Prompt replacement of worn seals will insure peak operating performance and trouble free operation. The water seals and their respective components sometimes referred to as the packing stack, will vary slightly between models. But the constant between models is that the packing stack will consist of the following items.*

*Piston Guides – which usually house the low-pressure seal
Low-Pressure Seals
Piston Guide O-Rings
High-Pressure Seals
Support Rings*

Torque Ratings Inch Pounds (ft.lbs)

Head	443 (37)
Valve Cap	443 (37)

Oil

AR64545 - Container is 4.5 fluid ounces

Specially formulated for the demands of the XJ and SJ pump series. Keep your pumps running strong and operating with normal temperature specs. **No** other oil is factory approved for these pumps.*



**Using any other oil may result in Drive End Damage.*

XJV-E 3400 RPM

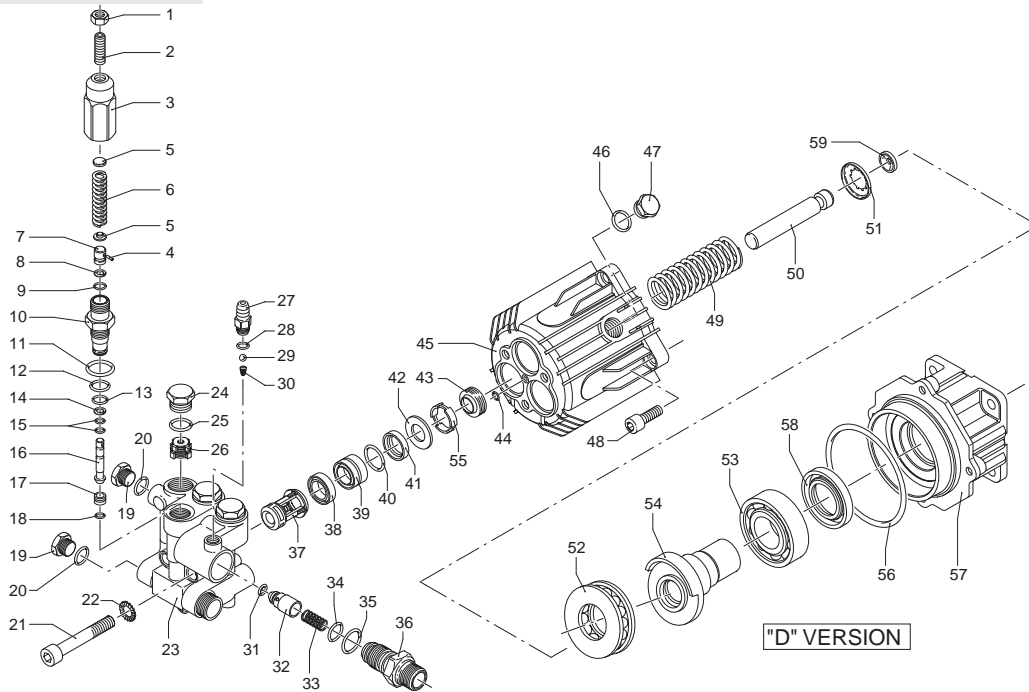

"D" VERSION

Pos.	Code	Description	Qty.	Pos.	Code	Description	Qty.
1	1980300	Nut	1	44	770090	O-Ring	1
2	392840	Adjustment screw	1	45	1980460	Crankcase	1
3	1980540	Adjustment cap	1	46	740290	O-Ring	1
4	1080070	Pin	1	47	1980740	Oil plug	1
5	1980220	Plate spring	2	48	180030	Bolt	4
6	1980520	Spring	1	49	1981140	Spring	3
7	1080041	Upper piston	1	50	1981440	Piston	3
8	1080401	Back-up ring	1	51	1980150	Piston retainer (3 pc)	3
9	1080250	O-Ring	1	52	1982290	Bearing	1
10	1980530	Piston guide	1	53	161060	Bearing	1
11	880830	O-Ring	1		1981540	Angle plate	○ 1
12	740290	O-Ring	1		1981610	Angle plate	□ 1
13	800560	O-Ring	1		1981620	Angle plate	▽ 1
14	1271170	Back-up ring	1	55	1980430	Retainer	3
15	1080190	O-Ring	2	56	1980340	O-Ring	1
16	1271160	Lower piston	1	57	1981420	Flange	1
17	1980200	Piston seat	1	58	1140380	Oil seal	1
18	1470210	O-Ring	1	59	1981130	Plunger shoe	1
19	880581	Plug 1/4G	2				
20	820510	O-Ring	2				
21	1980310	Head bolt (443 in/lbs)	3				
22	650530	Washer	3				
23	1981500	Pump head	1				
24	1260162	Valve cap (443 in/lbs)	3				
25	960160	O-Ring	3				
26	1989061	Complete valve	6				
27	1560490	Chem barb	1				
28	480480	O-Ring	1				
29	1250280	Ball	1				
30	1560520	Spring	1				
31	1460430	O-Ring	1				
32	1540170	Check valve	1				
33	1080091	Spring	1				
34	394280	O-Ring	1				
35	1200690	O-Ring	1				
36	1271700	Detergent injector	1				
37	1989060	Complete valve	3				
38	2460180	High pressure packing	3				
39	1981470	Piston guide	3				
40	770130	O-Ring	3				
41	1260440	Low pressure seal	3				
42	1980170	Seal retainer	3				
43	1980410	Oil seal	3				

Legend

For ○	For □	For ▼
XJV-E2G15	XJV-E2.5G15	XJV-E3G15
XJV-E2G20	XJV-E2.5G20	XJV-E3G20
	XJV-E2.5G22	XJV-E3G22

Repair Kits

Water Seals	Valves	Pistons	Oil Seals
Kit 2582	Kit 2581	Kit 2593	Kit 2511

Pos.	Qty.	Pos.	Qty.	Pos.	Qty.	Pos.	Qty.
38	3	26	3	50	3	43	3
40	3	37	3			44	1
41	3					56	1
42	3						
55	3						

Unloader Kit

Kit 2594			
Pos.	Qty.	Pos.	Qty.
1	1	10	1
2	1	11	1
3	1	12	1
4	1	13	1
5	2	14	1
6	1	15	2
7	1	16	1
8	1	17	1
9	1	18	1

Oil Capacity and Torque Specifications

inch pounds
(ft. lbs.)



PUMP SERIES	OIL CAPACITY	HEAD	PISTON NUT	REAR COVER	SIDE COVER	VALVE CAP	CON RODS
XJ/SJ SERIES	4.5 oz	443 (37)	N/A	228 (19)	N/A	443 (37)	N/A
XT SERIES							
FLAT COVER ≤1740 PSI	8 oz	89 (7.5)	106 (8.8)	48 (4.0)	N/A	300 (25)	N/A
EXT. COVER ≥1740 PSI	10 oz	137 (11)	106 (8.8)	48 (4.0)	N/A	300 (25)	N/A
XRC SERIES	15 oz	217 (18)	106 (8.8)	89 (7.5)	217 (18)	478 (40)	71 (5.9)
XM / SXM / GXMV SERIES	14 oz	133 (11)	106 (8.8)	106 (8.8)	N/A	442 (37)	N/A
XW / SXW SERIES	32 oz	442 (37)	106 (8.8)	89 (7.5)	217 (18)	602 (50)	89 (7.5)
RK / RKSS / GRKV SERIES	15 oz	217 (18)	106 (8.8)	89 (7.5)	217 (18)	478 (40)	N/A
XMA-SS SERIES	14 oz	80 (6.6)	106 (8.8)	106 (8.8)	N/A	443 (37)	N/A

OIL	OIL CHANGE
-----	------------

AR64516	<ul style="list-style-type: none"> • First change after 50 hours of use. • Then every 500 hours. • This oil is specially formulated to provide correct lubrication properties for our pumps. No other oil is factory approved for these pumps.
---------	--

AR64545 XJ/SJ Series ONLY	<ul style="list-style-type: none"> • Do NOT change oil. Use oil only to add if low. • This oil is specially formulated for the demands of the XJ and SJ pump series. No other oil is factory approved for these pumps.
---------------------------	--